

Pro**Meister**

User Guide

Max 12V Li-ion Impact Driver

Schlagschrauber
Slagskrudragare
Slagbormaskin

Slagskruemaskine
Akkuisuruuvinväännin

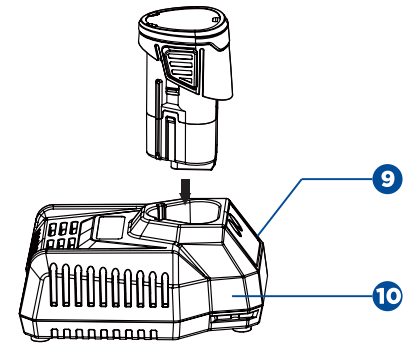
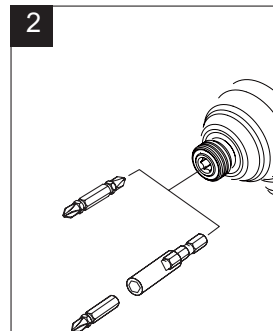
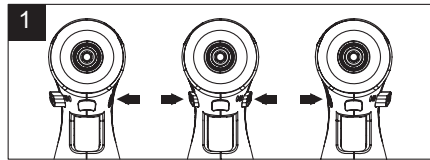
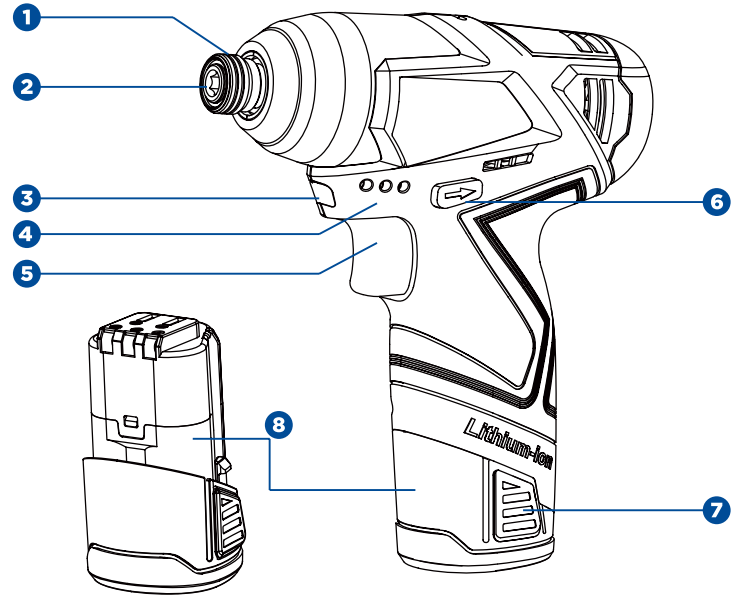

Introduction

Your new ProMeister power tool will more than satisfy your expectations. It has been manufactured under stringent ProMeister quality standards to meet superior performance criteria. You will find your new tool easy and safe to operate and with proper care, it will give you many years of dependable service.



WARNING:





Carefully read through this entire Instruction Manual before using your new ProMeister power tool. Take special care to heed the Warnings, Your ProMeister power tool has many features that will make your job faster and easier. Safety, performance and dependability have been given top priority in the development of this tool, making it easy to maintain and operate.



Do not dispose of electrical products together with household waste!

Waste electrical products should not be disposed of with household waste. Please recycle where facilities exist. Check with your local authority or retailer for recycling advice.

Description of Symbols

V	Volts	Voltage
A	Amperes	Current
Hz	Hertz	Frequency (cycles per second)
W	Watt	Power
min	Minutes	Time
~	Alternating Current	Type of Current
≡	Direct Current	Type or a characteristics of current
	Class II Construction	Double-insulated construction
	Before charging, read the instructions	To reduce the risk of injury, user must read and understand the user guide before using this product.
	Safety Certification	Conformance to use the CE mark and complies with relevant standards.
	Safety Alert	Precautions that involve your safety
	For Indoors Use Only	To reduce the risk of electric shock, only using the charger indoor.

Technical Data

1. Art. Nr:	PT7501
2. Motor:	Max 12V DC
3. Variable Speed:	0-2200r/min (no-load)
4. Max. Torque:	100Nm
5. Work Light:	LED

NOISE AND VIBRATION INFORMATION (measured values determined according to EN 60745)

• Noise Emission

A-weighted sound pressure level LPA: 91 dB(A),

Uncertainty KpA: 3dB(A)

A-weighted sound power level LWA: 102dB(A)

Uncertainty KpA: 3dB(A)

• Vibration Emission

ah = 10m/s² K=1.5m/s²

- The declared vibration total value has been measured in accordance with a standard test method and may be used for comparing one tool with another;
- The declared vibration total value may also be used in a preliminary assessment of exposure;
- The vibration emission during actual use of the power tool can differ from the declared total value depending on the ways in which the tool is used;
- Of the need to identify safety measures to protect the operator that are based on an estimation of exposure in the actual conditions of use (taking account of all parts of the operating cycle such as the times when the tool is switched off and when it is running idle in addition to the trigger time).

Battery

- Art. Nr:PT7801 Max 12V DC, 2.0Ah

Charger

- Art. Nr:PT7803
- Input: 220-240V AC, 50Hz
- Consumption: 48W
- Output: 12V,3A
- Charger Time: 45min
- Optimum Charging Temperature: 0°-45°C

General Power Tool Safety Warning

⚠ WARNING: Read all safety warnings and all instructions. Failure to follow the warnings and instructions may result in electric shock, fire and/or serious injury. **Save all warnings and instructions for future reference.** The term "power tool" in the warnings refer to your mains-operated (corded) power tool or battery-operated (cordless) power tool.

1) Work Area Safety

- **Keep work area clean and well lit.** Cluttered or dark areas invite accidents. Rags, cloths, cord, string and similar items should never be left around the work area
- **Do not operate power tools in explosive environments,** such as in the presence of flammable liquids, gases or dust. Power tools create sparks which may ignite the dust or fumes.
- **Keep children and bystanders away while operating a power tool.** Distractions can cause the operator to lose control.

2) Electrical Safety

- **Power tool plugs must match the outlet. Never modify the plug in any way. Do not use any adapter plugs with grounded power tools.** Unmodified plugs and matching outlets will reduce risk of electric shock.
- **Avoid body contact with grounded surfaces such as pipes, radiators, ranges and refrigerators.** There is increased risk of electric shock if your body is grounded.
- **Do not expose power tools to rain or wet conditions.** Water entering a power tool will increase the risk of electric shock.
- **Do not abuse the cord. Never use the cord for carrying, pulling or unplugging the power tool. Keep cord away from heat, oil, sharp edges or moving parts. Replace damaged cords immediately.** Damaged or entangled cords increase the risk of electric shock.
- **When operating a power tool outdoors, use an extension cord suitable for outdoor use.** Use of a cord suitable for outdoor reduces the risk of electric shock.

3) Personal Safety

- **Stay alert at all times when operating a power tool. Do not use a power tool while you are tired or under the influence of drugs, alcohol or medication.** A moment of inattention while operating power tools may result in serious personal injury.
- **Use personal protective equipment. Always wear eye protection that meets OSHA and ANSI Z87.1 standards.** Protective equipment such as dust mask, non-skid safety shoes, hard hat or hearing protection will reduce personal injuries.
- **Prevent unintentional starting. Ensure the switch is in the "off" position before connecting to power source and/or battery pack, picking up or carrying the tool.** Carrying power tools with your finger on the switch or energising power tools that have the switch on invites accidents.
- **Remove any adjusting key or wrench before turning the power tool on.** A wrench or key left attached to a rotating part of the power tool may result in personal injury.
- **Do not overreach. Keep proper footing and balance at all times.** This enables better control of the power tool in unexpected situations.
- **Dress properly. Do not wear loose clothing or jewellery. Keep your hair, clothing and gloves away from moving parts.** Loose clothes, jewellery or long hair can be caught in moving parts.

General Power Tool Safety Warning

- **If devices are provided for the connection of dust extraction and collection facilities ensure these are connected and properly used.** Use of dust collection can reduce dust-related hazards.

4) Power Tool Use and Care

- **Do not force the power tools. Use the correct power tool for your application.** The correct power tool will do the job better and safer at the rate for which it was designed.
- **Do not use the power tool if the switch does not turn it "on" and "off".** Any power tool that cannot be controlled with the switch is dangerous and must be repaired.
- **Disconnect the plug from the power source and/or the battery pack from the power tool before making any adjustments, changing accessories or storing power tools.** Such preventive safety measures reduce the risk of starting the power tool accidentally.
- **Store idle power tools out of the reach of children and do not allow persons unfamiliar with the power tool or these instructions to operate the power tool.** Power tools are dangerous in the hands of untrained users.
- **Maintain power tools with care. Check for misalignment or binding of moving parts, breakage of parts and any other condition that may affect the power tool's operation.** If damaged, have the power tool repaired before use. Many accidents are caused by poorly maintained power tools.
- **Keep cutting tools sharp and clean.** Properly maintained cutting tools with sharp cutting edges are less likely to bind and are easier to control.
- **Use the power tool, accessories and tool bits etc. in accordance with these instructions, taking into account the working conditions and the work to be performed.** Use of the power tool for operations different from those intended could result in a hazardous situation.

5) Use and Care of the Battery Pack

- **Verify that the switch is in the "off" position before inserting the battery pack.** Inserting the battery pack into a power tool that has the switch in the "on" position invites accidents
- **Recharging only with the charger specified by the manufacturer.** A charger that is suitable for one type of battery pack may create a risk of fire when used with another battery pack.
- **Use power tools only with specifically designated battery packs.** Use of any other battery packs may create a risk of injury and fire.
- **When the battery pack is not in use, keep it away from other metal objects like paper clips, coins, keys, nails, screws or other small metal objects that can create a connection between the terminals.** Shorting the battery terminals together may cause burns or a fire.
- **Avoid contact with any liquid that is emitted by a battery.** If the battery pack is abused, liquid may escape from the battery. Liquid emitted from the battery may cause irritation or burns. If liquid comes into contact with the skin, wash the area immediately with soap and water then neutralize the liquid with lemon juice or vinegar. If contact occurs, rinse thoroughly with running water. If liquid comes into contact with the eyes, rinse thoroughly with running water and seek medical help.
- **Store battery pack in well ventilated, dry and cool conditions and avoid direct sunlight and rain.**

6) Servicing

- **Have your power tool serviced by a qualified repair person using only identical replacement parts.** This will ensure that the safety of the power tools is maintained.

Safety Warnings for Cordless Screwdriver

- **Wear ear protectors when impact drilling.** Exposure to noise can cause hearing loss.
- **Hold power tools by insulated gripping surfaces.** When performing an operation where the cutting accessory or fastener may contact hidden wiring. Cutting accessory and fasteners contacting a "live" wire may make exposed metal parts of the power tool "live" and could give the operator an electric shock.
- **Use appropriate detectors to determine if utility lines are hidden in the work area or call the local utility company for assistance.** Contact with electric lines can lead to fire and electric shock. Damaging a gas line can lead to explosion. Penetrating a water line causes property damage or may cause an electric shock.
- **Switch off the power tool immediately when the tool inserts jams. Be prepared for high reaction torque that can cause kickback.** The tool inserts jams when:
 - the power tool is subject to overload or
 - it becomes wedged in the workpiece.
- **Hold the machine with a firm grip.** High reaction torque can briefly occur while driving in and loosening screws.
- **Secure the workpiece.** A workpiece clamped with clamping devices or in a vice is held more secure than by hand.
- **Keep your workplace clean.** Blends of materials are particularly dangerous. Distance from light alloys can burn or explode.
- **Do not open the battery.** Danger of short-circuiting.
- **In case of damage and improper use of the battery, vapours may be emitted. Provide for fresh air and seek medical help.** The vapours can irritate the respiratory system.
- **Use the battery only in conjunction with your ProMeister powertools.** This measure alone protects the battery against dangerous overload.
- **Use only original ProMeister batteries with the voltage listed on the nameplate of your power tool.** When using other batteries, e.g. imitations, reconditioned batteries or other brands, there is danger of injury as well as property damage through exploding batteries.

Additional Instructions for Work with the Charger

- Before using the charger, read all the instructions and cautionary markings on the charger and battery pack as well as the instructions on using the battery pack.
- Only charge your batteries indoors as the charger is designed for indoor use only.

 **WARNING: If the battery pack is cracked or damaged in any other way, do not insert it in the charger. There is a danger of electric shock.**

 **WARNING: Do not allow any liquid to come into contact with the charger. There is a danger of electric shock.**

Additional Instructions for Work with the Battery Pack

 **WARNING: If the battery pack is cracked or damaged in any other way, do not insert it in the charger. There is a danger of electric shock.**

Fitting and Removing the Battery Pack

To remove the battery from the machine, press the battery release buttons (7) and take the battery out of the tool.

 **WARNING: Always set the forward/reverse switch (6) in central position before any work on the machine e.g. fitting and removing a battery, changing the bit, transport, maintenance and storage.**

To install the battery: Insert the charged battery into the opening at the base of the power tool until the battery is securely latched with a click.

BATTERY CHARGING

- Insert the plug of the charger in the socket. The green LED on the charging indicator (9) will start to glow thus indicating that the charger is in standby state.
- Insert the battery (8) in the charger socket (10) considering the polarity.
- A new battery will work properly after five cycles of charging and discharging. Charge and discharge a battery, which is not used for a long time, for two to three times to function well.
- When the battery working time is remarkably short despite full charging, the life of the battery may be over. Replace the battery immediately.

 **WARNING: The battery will be fully charged after approximately 60 minutes, remove it from the charger after this time.**

CHARGING INDICATION

1. Plug in the plug into the mains supply. The green LED will display.
2. Insert the battery pack into the charger base. The red LED will light and the same time the green one will turn off.
3. The charging process will last approx. 60 min and be displayed by red permanent lighting of the LED. The charge will be completed when the red LED goes out and the green LED lights up.

Additional Instructions for Work with the Charger

! CAUTION! If the red or green LED keeps flashing during the charging process for more than 20 minutes, please remove the battery and allow cooling down for 15-30 minutes. Then insert it into the charger base again, if LED still flashes, the battery and charger require service.

Note:

1. If the battery pack is still hot to hold, allow to cool for a 30 min and reinsert. The charger will not charge a hot battery.
2. Charger may warm with several continuous charge cycles. This is part of the normal operation of the charge. Charge in a well ventilated area.

BATTERY STATE INDICATION

The battery state during operation can be checked on the LED display (4) by pressing the switch (5)

Depending on the number of illuminated LEDs the battery state is as follows:

3=battery 100%-60% charged

2=battery 60%-30% charged

1=battery <30% charged. It is necessary to recharge the battery.

Know and Operate Your Drill

Before using the power tool, familiarize yourself with all operating features and safety requirements. Use the tool and accessories only for the applications intended. All other applications are expressly ruled out.

1 Locking Sleeve	2 Bit Holder	3 LED Work Light
4 LED Battery	5 ON/OFF Trigger Switch	6 Forward Reverse Switch
7 Battery Release Buttons	8 Battery	9 LED Charge State Indicator
10 LED Charge State Indicator		

LED WORK AREA LIGHT

The machine is equipped with LED worklight (3) to illuminate the work area and improve visibility when drilling in areas with insufficient light. To turn the LED light on and off depress the LED light button (5).

REVERSING

The extreme position of lever (6) to the right (viewed from the rear) is equivalent to anti-clockwise rotation, the extreme position to the left is to clockwise rotation. When the ON/OFF switch (5) is depressed, lever (6) cannot be actuated. (fig.1)

! WARNING: Reversing can be performed only when the spindle is not rotating!

Drilling is performed with lever in extreme position to the left.

Reversing is performed with lever in extreme position to the right.

SWITCHING ON-SWITCHING OFF

Switching on: press ON/OFF switch (5).

Switching off: release ON/OFF switch (5).

The power tool is equipped with a brake. The spindle stops rotating immediately after releasing the switch lever.

SMOOTH ELECTRONIC RPM CONTROL

Light pressure on ON/OFF trigger switch (5) results in low rotation speed, further pressing the switch results in smooth increase of the rpm to maximum upon reaching the extreme position.

OPERATING THE TOOL

Impact operation starts automatically when the load exceeds certain level. Pushing the trigger switch at on load will result only in change of speed.

The fastening torque depends on the duration of impact operation. Generally, maximum torque is achieved after 6 to 10 seconds of impact operation. Further operation will result only in slight torque increase. Prolonged impact operation may cause motor damage or burning.

Know and Operate Your Drill

The torque depends on the length, grade and diameter of the screw. It depends also on the strength of material to be fastened (wood, metal, etc.) and the type of washer used. Operate the tool after calculating the appropriate impact operation time by performing a trial fastening and measuring the actually achieved torque by a torque wrench. The torque depends on the length, grade and diameter of the screw. It depends also on the rigidity of material to be fastened (wood, metal, etc.) and the type of washer used. Operate the tool after calculating the appropriate impact operation time by performing a trial fastening and measuring the actually achieved torque by a torque wrench.

INSERTING AND REMOVING BITS (Fig. 2)

! WARNING: Remove the battery or set the forward/reverse switch (6) in central position

Inserting the bit:

1. Pull the locking sleeve (1) forward.
2. Insert the bit into the hexagonal socket of the bit holder (2).
3. Release the locking sleeve, it will return in its initial position and secure the bit.

! WARNING: If the locking sleeve does not return to its original position, then the bit has not been installed properly.

Removing the bit:

1. Pull the locking sleeve forward and keep it in this position to remove the bit.

Screwing / Unscrewing

1. Install a bit that matches the screw, align the bit into the grooves of the screw head, and then tighten it.
2. Push the impact driver just enough to keep the bit in contact with the screw head.

! WARNING: Overtightening may result in breaking the screw or damaging the bit!

Applying the impact driver for too long may tighten the screw too much and break it.

- Tightening with the impact driver not aligned with the screw may damage the screw head and the driving force will not be transmitted properly to the screw.
- Before screwing large long screws into hard material, it is advisable to pre-drill a pilot hole with the core diameter of the thread to depth approx. 2/3 of the screw length.

Maintenance

! WARNING: Always set the ON/OFF trigger switch (5) in central position before any work on the machine e.g. fitting and removing a battery pack, changing the bit, transport, maintenance and storage.

Regularly check that all the fixing screws are tight. They may vibrate loose over time.

CLEANING

For safe operation, always keep the machine and its ventilation slots clean. Regularly check to see if any dust or foreign matter has entered the grills near the motor and around the switches. Use a soft brush to remove any accumulated dust. Wear safety glasses to protect your eyes while cleaning. If the body of the tool needs cleaning, wipe it with a soft damp cloth. A mild detergent can be used.

! WARNING: Never use alcohol, petrol or other cleaning agent. Never use caustic agents to clean plastic parts.

CHARGER CLEANING INSTRUCTIONS

! WARNING: Disconnect the charger from the AC outlet before cleaning.

- Dirt and grease may be removed from the exterior of the charger using a cloth or soft non metallic brush. Do not use water or any cleaning solutions.

IMPORTANT! To assure product safety and reliability, repairs, maintenance and adjustment (including brush inspection and replacement) should be performed by certified service centers or other qualified service organizations, always using genuine replacement parts.

Environmental Protection

- The machine, rechargeable batteries, accessories and packaging should be sorted for environmental-friendly recycling.
- Do not dispose of power tools and batteries/rechargeable batteries into household waste!

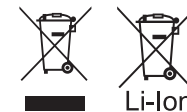

According to the European Guideline 2002/96/EC for Waste Electrical and Electronic Equipment and its implementation into national right, power tools that are no longer usable must be collected separately and disposed of in an environmentally correct manner.

ATTENTION! Batteries must be removed from battery-powered tools and disposed of separately in accordance with 2006/66/EC. Batteries must never be disposed of with domestic waste!

Collection and disposal of packaging materials separately by types complying with local rules and regulations. For details, please contact your municipal authority concerned.

EC Declaration of Conformity

We, *Bileko Car Parts AB*
P.O. Box 542,
S-645 25 Strängnäs,
Sweden

Herewith declare that the following machine complies with the appropriate basic safety and health requirements of the EC Directive based on its design and type, as brought into circulation by us.

In case of alteration of the machine, not agreed upon by us, this declaration will lose its validity:

Description: *Battery charger*
Type: *Art nr: PT7501 charger*
Applicable EC Directives:
Low Voltage Directive: 2014/35/EU
EMC Directive: 2014/30/EU
RoHS Directive: 2011/65/EU
WEEE Directive: 2012/19/EU

Applicable Harmonized Standards:
EN 60335-1:2012/A13:2017
EN 60335-2-29:2004/A2:2010
EN 55014-1:2006/A2:2011
EN 55014-2:2015
EN 61000-3-2:2014
EN 61000-3-3:2013
EN 50581:2012

Date / Authorized Signature: 2020-01-02

Title of Signatory: *Albin Karlsson*
Purchasing & Category Manager
Business area: Workshop equipment, Consumables & Tools



EC Declaration of Conformity

We, *Bileko Car Parts AB*
P.O. Box 542,
S-645 25 Strängnäs,
Sweden

Herewith declare that the following machine complies with the appropriate basic safety and health requirements of the EC Directive based on its design and type, as brought into circulation by us.

In case of alteration of the machine, not agreed upon by us, this declaration will lose its validity:

Description: *Cordless impact drill driver*
Type: *Art nr: PT7501*
Applicable EC Directives:
Machinery Directive: 2006/42/EC
EMC Directive: 2014/30/EU
RoHS Directive: 2011/65/EU
WEEE Directive: 2012/19/EU

Applicable Harmonized Standards:
EN 62841-1:2015
EN 62841-2-2:2014
EN 55014-1:2017
EN 55014-2:2015
EN 50581:2012

Date / Authorized Signature: 2020-01-02

Title of Signatory: *Albin Karlsson*
Purchasing & Category Manager
Business area: Workshop equipment, Consumables & Tools



Produced in China for
Bileko Car Parts AB
P.O. Box 542
S-645 25 Strängnäs, Sweden
Tel: +46 771 72 00 00
www.promeister.com

