

Application

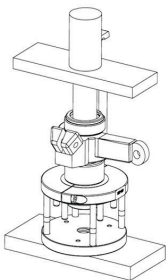

Please secure the separate parts properly!
Please lubricate the threaded spindle before each use!

Fig 6



Wheel hub installation with the help of a workshop press

- Before pressing down the bearing with the plunger, please make sure that all parts are aligned and centered. Then press down the bearing with regulated pressure on the wheel hubs with an internal diameter of 48mm.
- First, insert the installation centering bushing (5) with the diameter 48mm pointing towards the bore hole of the wheel hub. Then slide the wheel bearing over the installation centering bushing (5)
- Place and press the bushing sleeve with regulated pressure.

Fig 7

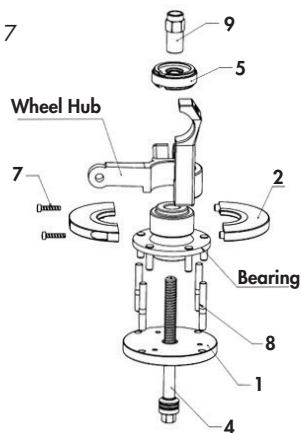

Installation of wheel bearing on wheel hub with threaded spindle (4) and spindle nut (9)

- Place the pressure plate (1) onto the opened vice jaws, then place the wheel hub on the vice as shown in the illustration.
- On the wheel hub, an Installing Back-up ring (2) has to be inserted on the side of the wheel hub as far as it will go.
- Use the box wrench to turn the spindle nut until the wheel bearing onto the wheel hub.

Fig 8

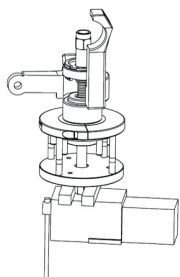

ProMeister

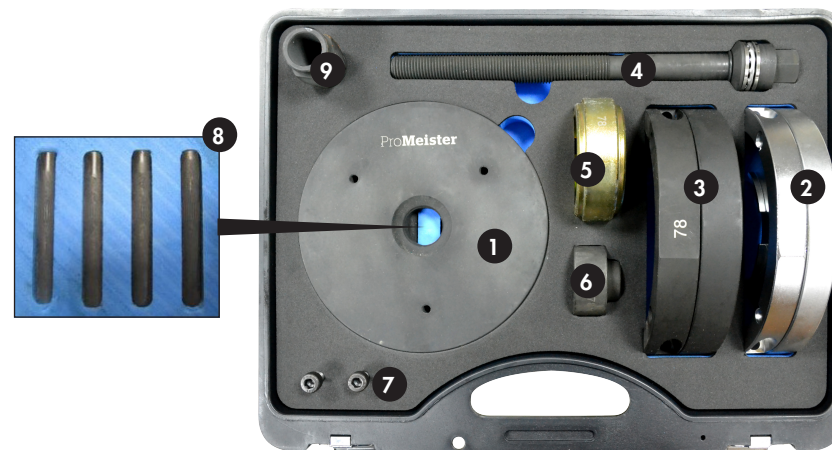

No.	1	2	3	4	5	6	7	8	9
Description	Pressure Plate	Installing Back-Up Ring	Removal Back-Up Ring	Spindle	Installing Centering Bushing	Removal Centering Bushing	Screw M8x35L	Forcing Bolt	Spindle Nut
Qty	1	1	1	1	1	1	2	4	1

User Guide

Wheel Hub Bearing Puller Set

Safety Precaution

- Please make to carefully read these operating instructions and fully understands all information given before it is used.
- These user guide contains important information that is necessary for a safe and trouble-free operation of your Wheel Hub Tool Set.
- For the effectivity of the Wheel Hub Tool Set, as its intended use, it is essential that all the safety and other information in these operating instructions are adhered to.
- For this reason, always keep his user guide together with your Wheel Hub Tool Set.
- This tool has been designed exclusively for specific applications. We emphasize that any modification to the tool and/or use on an application not detailed to its intentions are strictly prohibited.
- We are not liable for any injuries to person(s) or damage to property originating from improper application, misuse of the tool or a disregard of the safety instructions.
- Furthermore, the general safety regulations and the regulations for the prevention of accidents valid for the application area of this tool must be observed and respected.
- Always keep the tool clean and the user guide together with the tool set at all times.
- All safety equipment must always be within reach and should be checked regularly.

Application



Please secure the separate parts properly!
Please lubricate the threaded spindle before each use!

Fig 1

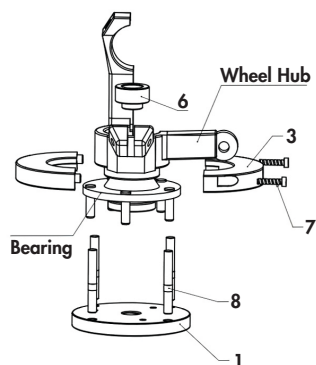

Wheel hub removal with the help of a workshop press

- Remove the wheel bearing and wheel hub out of the spring strut.
- Insert the 4 forcing bolts (8) into the locating hole of the pressure plate (1).
- Insert both halves of the removal back-up ring (3) sideways between the wheel bearing and the wheel hub. Then screw them together with the 2 cylinder screws (7) M8x35.
- Put the bearing unit onto the forcing bolts (8) in a way that the forcing bolts (8) pass through the threaded holes of the wheel hub against the removal back-up ring (3).

Fig 2

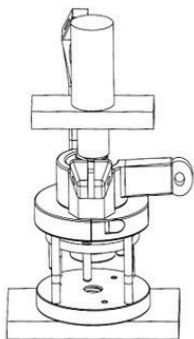

- Lay the wheel bearing with the wheel hub and the installed tools onto the press table with the pressure plate downwards.
- Insert the removal centering bushing (6) into the wheel bearing.
- Adjust the wheel bearing with the tools installed so that the press head's pressure is applied right onto the center of the removal centering bushing (6).
- Operate the workshop press until the wheel hub is separated from the bearing.
- After removing the wheel hub, remove the attached parts.

Application



Please secure the separate parts properly!
Please lubricate the threaded spindle before each use!

Fig 3

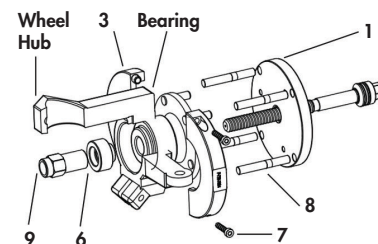

Wheel hub removal with the help of spindle (4) and spindle nut (9)

- Remove the wheel bearing with the wheel hub out of the spring strut.
- Insert both halves of the removal back-up ring (3) sideways between the wheel bearing and the wheel hub and screw them together with the 2 cylinder screws (7) M8x35.
- Put the threaded spindle (4) and the pressure plate (1) with 4 forcing bolts (8) inserted onto the wheel bearing/wheel hub in a way that the forcing bolts (8) pass through the threaded holes of the wheel hub, against the removal back-up ring (3).
- Slide the removal centering bushing (6) over the spindle up to the wheel bearing's front end.
- Screw the spindle nut (9) onto the spindle.

Fig 4

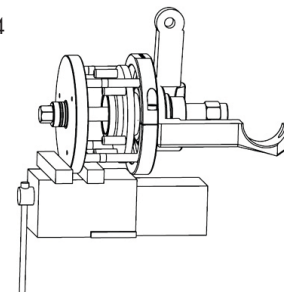

Wheel hub removal with the help of spindle (4) and spindle nut (9) with clamp

- Clamp the wheel bearing unit with the wheel hub and the connected tools into a Machinist's vice.
- Once the required connection has been reached, it is necessary to retain the spindle nut (9) with a screw driving tool (e.g. box wrench) until the wheel hub is separated from the bearing.
- After the wheel hub removal, then remove the attached parts.

Fig 5

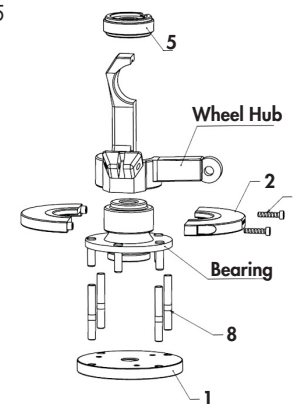

Wheel hub installation with the help of a workshop press

- Lay the pressure plate (1) onto the press table.
- Place the wheel hub onto the Pressure plate (1) as shown in the illustration. With an internal diameter of 88mm on the wheel hub which the installation back-up ring (2) has to be inserted on the side of the bearing as far as it will go.
- Place both parts with the bore hole downwards onto the wheel hub. The installation centering bushing (5) centers in the bore hole of the wheel hub.
- Afterwards, slip the pressure sleeve top-down over the installation centering bushing (5).